

FUEL PRESSURE THREAD ADAPTER FOR FORD SUPER DUTY 7.3 POWERSTROKE

1. Disconnect the battery cables from the negative posts of the batteries.
2. Remove the fitting from the pressure port on the passenger side of the fuel filter housing that is facing the firewall using a 3/16" Allen key.
3. Thread the fuel pressure adapter into the fuel filter housing's pressure port.
 - Be sure to tighten the fuel pressure adapter so that the supplied o-ring seals the pressure port on the fuel filter housing.
4. Install your fuel pressure sensor directly into the female end of the fuel pressure adapter.
 - Be sure to use Teflon tape on the sensor threads to ensure a tight seal.
5. Finish installing your fuel pressure gauge by following the instructions that are included with it.

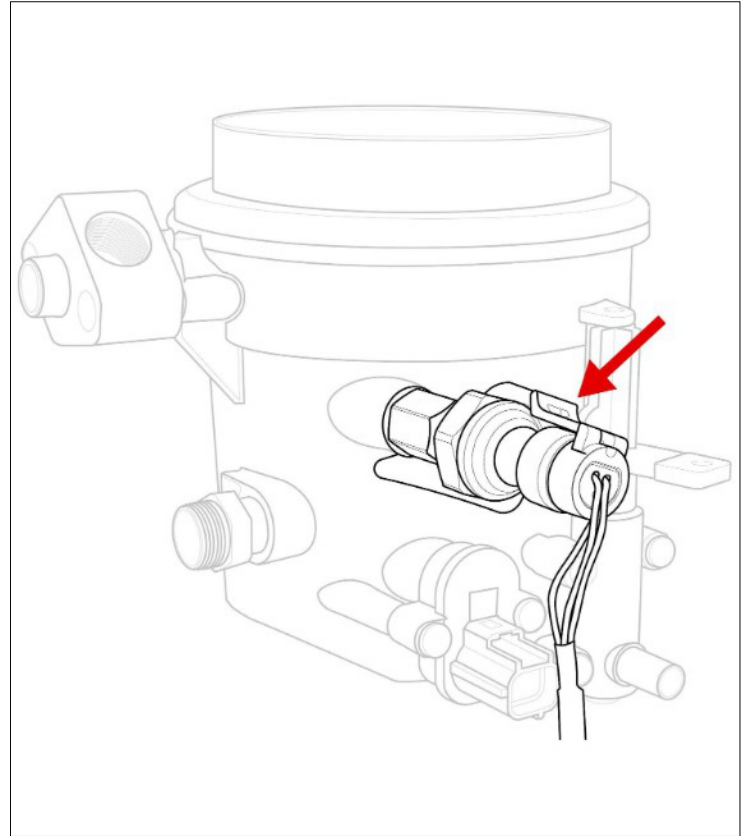



ONE YEAR NON-TRANSFERABLE LIMITED WARRANTY AND DISCLAIMER

MaxTow Performance, LLC. ("MaxTow") warrants to the original retail consumer purchaser, and not any other purchaser or subsequent owner, that this Product will be free from defects in material or workmanship for a period of **one (1) year** from the purchase date.

For a period of **one (1) year** from the date of purchase, at no charge to the Purchaser, MaxTow will repair or replace this Product if it is determined by MaxTow to be defective. After the warranty period, the Purchaser must pay all charges for parts and labor.

Coverage under this warranty is only valid within the United States, including its territories, as well as in certain other countries. Purchasers should check our website, www.MaxTow.com, to determine the warranty coverage in the countries in which they are located.

MaxTow does **not warrant the installation** of the Product, which is the sole responsibility of the Purchaser. Installation should be done by licensed professionals. Improper installation may cause damage to the Product and any vehicle in which it is installed, and may cause burns and electrical injury to individuals. MaxTow's warranty does not cover any expenses incurred in removing Products that are defective or re-installing replacement Products in their place.

During the warranty period, to have the Product repaired or replaced, the Purchaser must return the Product, freight prepaid by the Purchaser, to MaxTow (but for customers in the contiguous United States, MaxTow will pay the shipping charges if any Product fails during the first thirty (30) days after purchase). The Product must be returned in its original carton or in a similar package affording an equal degree of protection. MaxTow will return the repaired or replaced Product, freight prepaid, to the Purchaser. MaxTow does not provide Purchasers with temporary replacement units during the warranty period or at any other time.

This limited warranty is non-transferable and will automatically terminate if the original retail consumer purchaser resells the Product or transfers the vehicle in which the Product is installed. An "original retail consumer purchaser" is a person who originally purchases the Product, or a gift recipient of a new Product that is in its original packaging and unopened.

This limited warranty is subject to all of the following terms and conditions:

TERMS AND CONDITIONS

1. NOTIFICATION OF CLAIMS; WARRANTY SERVICE: If Purchaser believes that a Product is defective in material or workmanship, written notice with an explanation of the claim shall be given promptly by Purchaser to MaxTow. All warranty claims must be made within the warranty period, and any Products returned to MaxTow must be shipped in accordance with MaxTow's procedures (including use of RMA numbers supplied by MaxTow after notification). The repair or replacement of any Product or part thereof shall not extend the original warranty period. The specific warranty on the repaired part only (not including gauge sensors) shall be in effect for a period of ninety (90) days following the repair or replacement of that part, or the remaining period of the Product warranty, whichever is greater. MaxTow does not provide a warranty on replacement gauge sensors.

2. EXCLUSIVE REMEDY; ACCEPTANCE: Purchaser's exclusive remedy and MaxTow's sole obligation is to supply (or pay for) all labor necessary to repair any Product found to be defective within the warranty period and to supply new or rebuilt replacements for defective parts. MaxTow will refund the purchase price for such Product only if repair or replacement fails to remedy the defect. Purchaser's failure to make a claim as provided in paragraph 1 above or continued use of the Product shall constitute an unqualified acceptance of such Product and a waiver by Purchaser of all claims thereto.

3. EXCEPTIONS TO LIMITED WARRANTY: MaxTow shall have no obligation to Purchaser with respect to any Product that is subjected to any of the following: abuse, improper use, negligence, accident, modification, failure to follow the operating procedures outlined in the user's manual, failure to follow the maintenance procedures in the service manual for the Product, attempted repair by non-qualified personnel, operation of the Product outside of the published environmental and electrical parameters, or if the Product's original identification (trademark, serial number) markings have been defaced, altered, or removed. MaxTow excludes from warranty coverage Products sold AS IS and/or WITH ALL FAULTS. MaxTow also excludes from warranty coverage any consumable items such as fuses and batteries.

All software and accompanying documentation furnished with, or as part of the Product is furnished "AS IS" (i.e., without any warranty of any kind), except where expressly provided otherwise in any documentation or license agreement furnished with the Product.

4. PROOF OF PURCHASE; REGISTRATION: The Purchaser's dated bill of sale must be retained as evidence of the date of purchase and to establish warranty eligibility. Registration of any Product or of this limited warranty is voluntary, and failure to register will not diminish any rights available under this warranty.

DISCLAIMER OF WARRANTY

EXCEPT FOR THE FOREGOING WARRANTIES, MAXTOW HEREBY DISCLAIMS AND EXCLUDES ALL OTHER WARRANTIES, EXPRESS OR IMPLIED, INCLUDING, BUT NOT LIMITED TO ANY IMPLIED WARRANTIES OF MERCHANTABILITY, FITNESS FOR A PARTICULAR PURPOSE, OR ANY WARRANTY WITH REGARD TO ANY CLAIM OF INFRINGEMENT THAT MAY BE PROVIDED IN SECTION 2-312(3) OF THE UNIFORM COMMERCIAL CODE OR IN ANY OTHER STATE STATUTE.

LIMITATION OF LIABILITY

THE LIABILITY OF MAXTOW, IF ANY, AND PURCHASER'S SOLE AND EXCLUSIVE REMEDY FOR DAMAGES FOR ANY CLAIM OF ANY KIND WHATSOEVER, REGARDLESS OF THE LEGAL THEORY AND WHETHER ARISING IN TORT OR CONTRACT, SHALL NOT BE GREATER THAN THE ACTUAL PURCHASE PRICE OF THE PRODUCT FOR WHICH SUCH CLAIM IS MADE. IN NO EVENT SHALL MAXTOW BE LIABLE TO PURCHASER FOR ANY SPECIAL, INDIRECT, INCIDENTAL, OR CONSEQUENTIAL DAMAGES OF ANY KIND INCLUDING, BUT NOT LIMITED TO, COMPENSATION, REIMBURSEMENT OR DAMAGES ON ACCOUNT OF THE LOSS OF PRESENT OR PROSPECTIVE PROFITS OR FOR ANY OTHER REASON WHATSOEVER.

GOVERNING LAW: This non-transferable limited warranty shall be governed by the law of the State of New Jersey, U.S.A., and the United States of America, excluding their conflicts of laws principles. The courts of Camden County, New Jersey, shall have the exclusive jurisdiction over any legal action with respect to this warranty.

This limited warranty gives specific legal rights. You may also have other rights that may vary from state to state or from country to country. Some states or countries do not allow the exclusion or limitation of incidental or consequential damages, so the above limitations and exclusions may not apply to you. You are advised to consult applicable state or country laws for a full determination of rights.