

Under Dash Gauge Pod for 1999-2004 Ford Super Duty

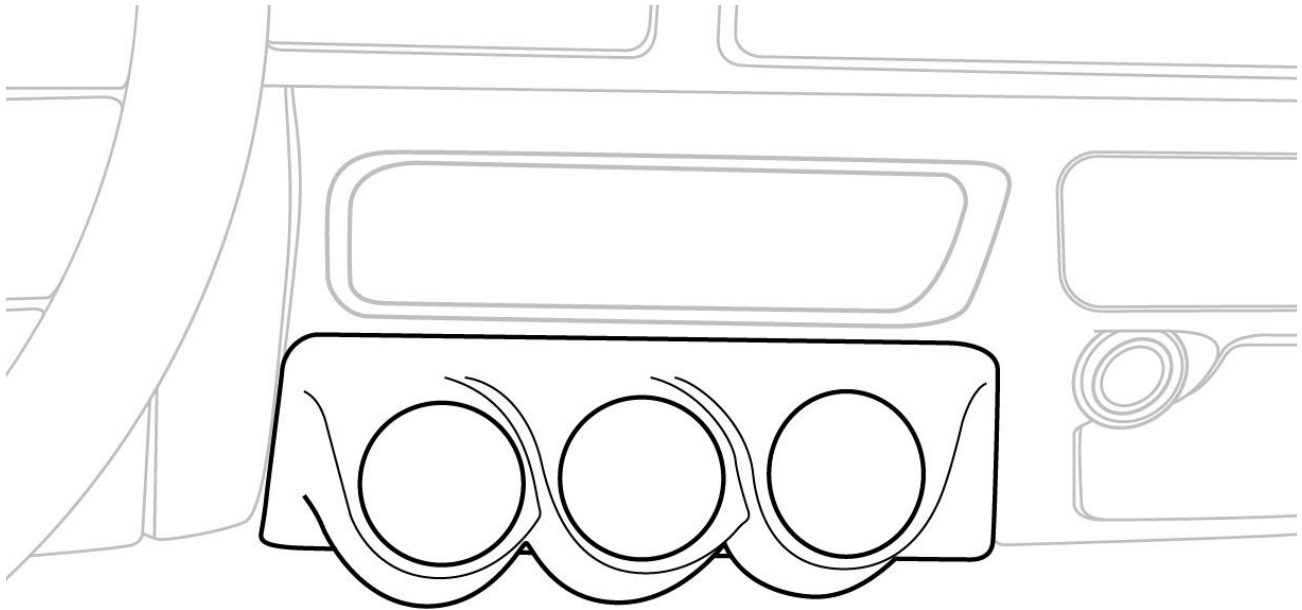

Note: This Under dash gauge pod will only fit trucks with an automatic transmission.

Installation Steps:

1. Position the under dash gauge pod along the lower edge of the dashboard, just beneath the radio, following the natural contour.
2. Ensure a seamless fit by making necessary adjustments, eliminating any gaps around the pod. Proceed to fasten the pod in place using the supplied screws.
3. Carefully guide the harnesses towards the under dash pod, ensuring they are neatly routed.
4. Finalize the gauge installation by referring to the specific gauge instructions provided. Follow these instructions to successfully complete the installation process.



Technical Support
1.877.7MaxTow
TechSupport@MaxTow.com
Mon thru Fri 9am to 6pm EST



All MaxTow Products are subject to the MaxTow Limited Warranty. Please visit <https://www.maxtow.com/warranty-policies> to review complete Warranty, Terms, and Conditions.